

+++++
Ubi Libertas Habitat...



... Nostra Patria Est.!



Brazosland Pistoleros

NEXT MATCH: April 27, 2008

MATCH SET-UP: 8:30 a.m.

SHOOTING STARTS: 10 a.m. or When the Match is Set-up

April 2008

Its that time again. Our match is this Sunday the 27th.

Brian is MD again this month and he has some challenging stages drawn up...better bring your dancing shoes. I really like the use of barrels on Barrels & Bullets. I think this match is a very good test of footwork and movement along with some very technical shooting.

Those two things, combined with the mental challenge of preparing a plan, and then executing that plan during the stage, are what make this sport so much fun. It will be easy to overrun targets and/or put a round where it shouldn't go with these stages...so work on your plan before you shoot and then stick to it.

Our four stages this month will be a total of about 95 rounds. Two stages are near 30 rounds each. This month more than ever we will need everyone's help taping and resetting. I like these stages. The classifier is one of the new ones and is a bit complicated, so try to read over it between now and the match.

Club dues are now due! \$25 a year. Those of you have not paid, please do so. Be sure to mark the sign up sheet with the amount you paid so that I can update your membership status.

Have you ordered your club t-shirt yet? Take a look at the link on our homepage and get your gear!

I regret to announce that I will not be shooting our match this weekend...I will be at the Tiger Valley 3 Gun in Waco. With our baby on the way in June, I don't know when I will be shooting another major 3 Gun (especially one that is over 400 rounds). So, when a spot opened up I had to take it...I'll miss seeing everyone on Sunday.

Don't forget to bring sunscreen and plenty of water as the weather warms up.

Shoot safe,

Kevin J.

Barrels & Bullets

RULES: Practical Shooting Handbook, Latest Edition **COURSE DESIGNER:** Brian Hagen A58003 March 2008

START POSITION: Shooters choice to start in either box A or box B. Hands relaxed at your sides. Gun loaded and holstered in ready condition per rule 8.1.1 and 8.1.2.	
STAGE PROCEDURE Upon start signal engage each target at they become visible keeping within the fault lines. Last target must be shot within the opposite box from start box. Steel must fall to score.	SCORING SCORING: Comstock, 30 rounds, points TARGETS: 13 IPSC, 2 PP, 2 Plates SCORED HITS: Best per IPSC, steel down = 1A START-STOP: Audible - Last shot PENALTIES: Procedural. -10 No-shoot hit. -10 Miss. -10

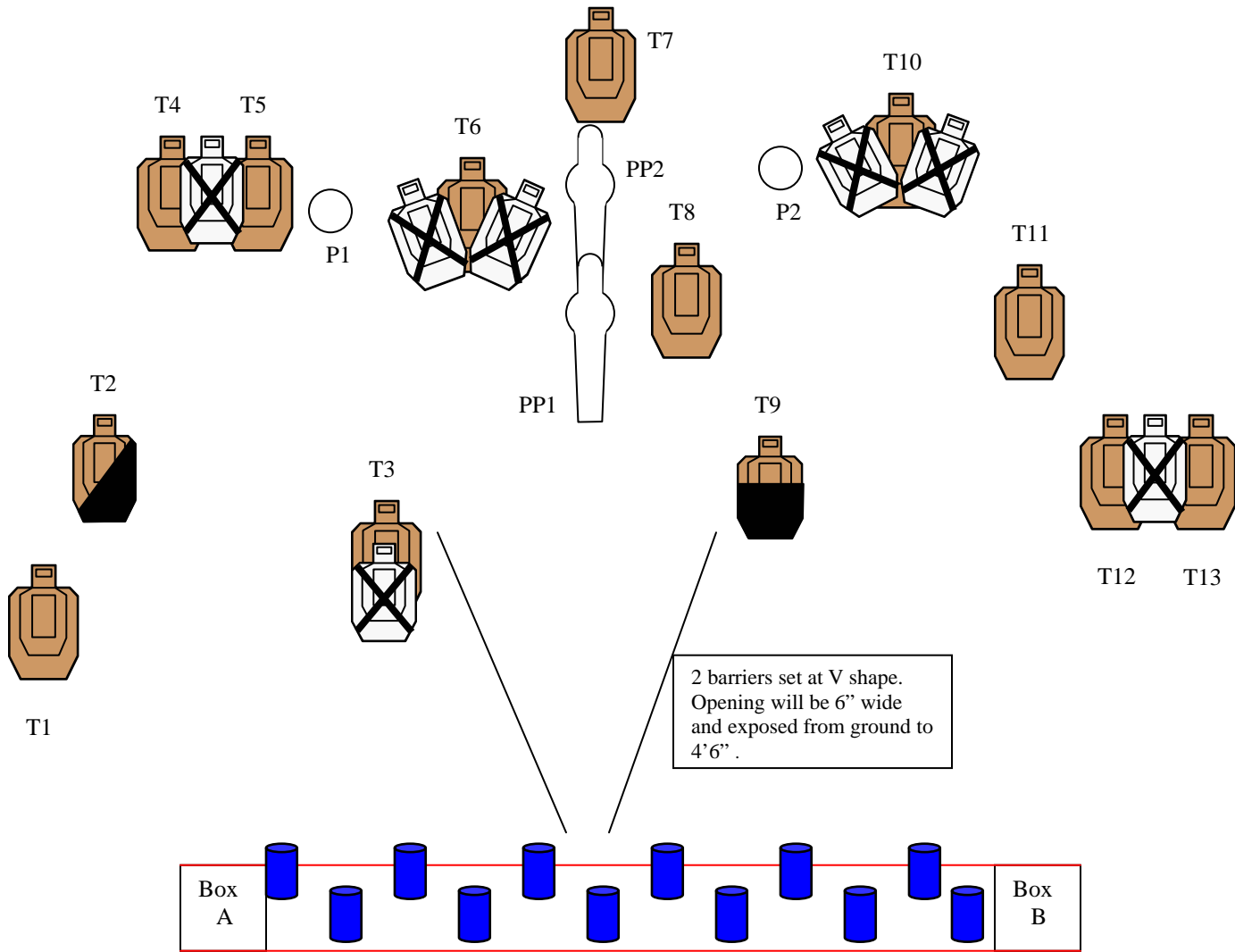

SETUP NOTES: Distance between fault lines should only be wide enough to be able to pass by the barrel to require shooter to zig zag. P1 & P2 will be set at 12" to center from ground. Point of "V" will be open from ground to 4'6" and will be covered from that point up. Gap in the "V" of 2 barriers will be 6".	RO NOTES:
--	------------------

Big's scrap yard

RULES: Practical Shooting Handbook, Latest Edition **COURSE DESIGNER:** Brian Hagen A58003

START POSITION: Standing in shooting box A, facing up range, toes of both feet against of rear of shooting box, shoulders square with box, and hands on ears or hearing protection. Handgun is loaded and holstered as per ready condition in rule 8.1.1 and 8.1.2.

STAGE PROCEDURE

Upon start signal turn and engage PP1 thru PP5, P1 and P2. No shoot target behind PP1, PP3 and PP5 will incur one penalty per hit. PP1 thru PP5, P1 and P2 must fall to score. All targets must be shoot from box A.

SCORING

SCORING: Comstock, 7 rounds, 35 points
TARGETS: IPSC, 3 PP, 2 USP
SCORED HITS: Best per IPSC, steel down = 1A
START-STOP: Audible - Last shot
PENALTIES: Procedural. -10
 No-shoot hit. -10
 Miss. -10

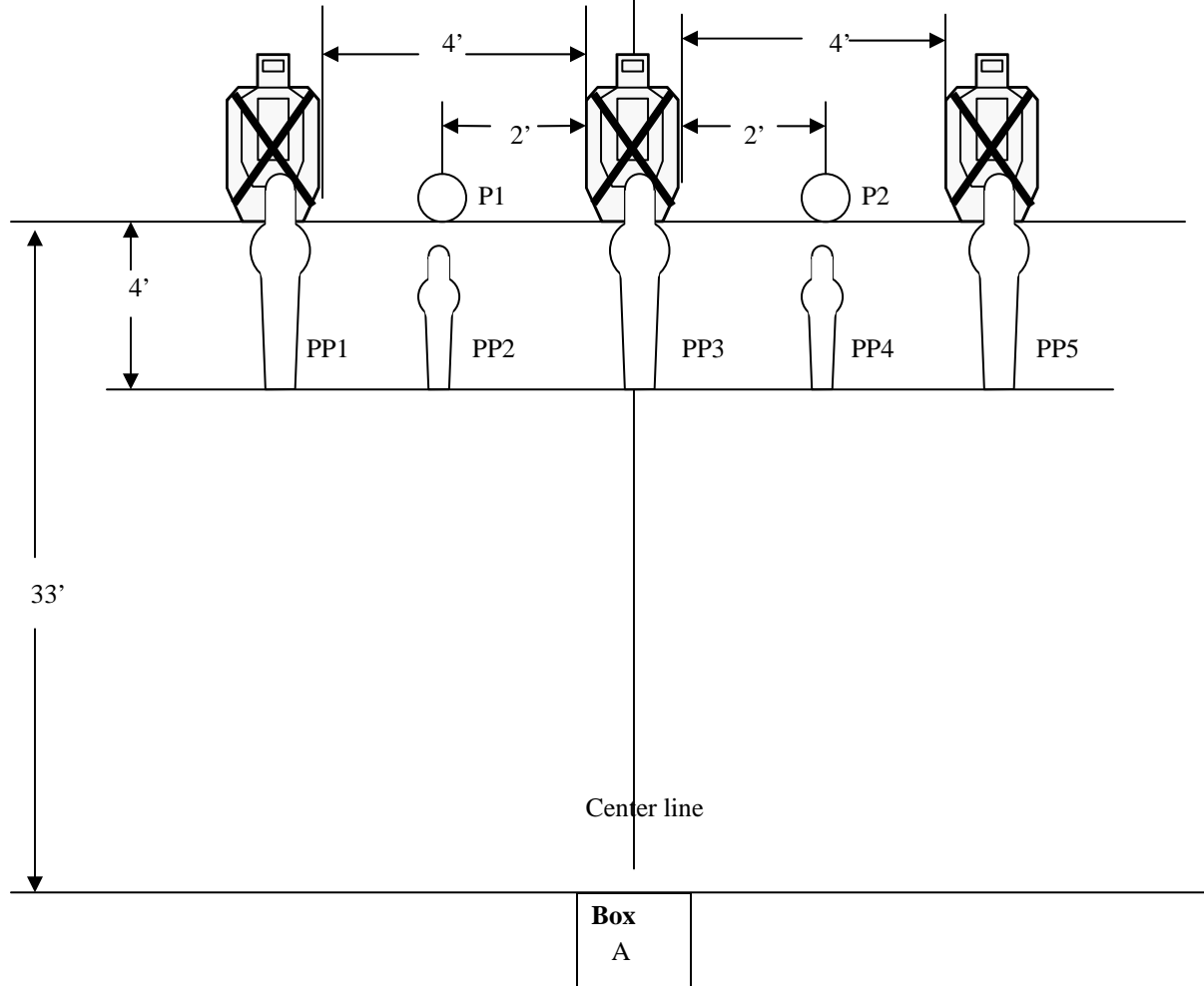

SETUP NOTES: No shoot targets are set at 3'6" at shoulders. PP1, PP3, PP5 are centered in front of no shoot targets. PP2 and PP4 are place in front of P1 and P2. P1 and P2 will be set off the ground to same height of center of PP2 and PP4 to conceal P1 and P2 from shooter.

RO NOTES:

Shooting up the alley

RULES: Practical Shooting Handbook, Latest Edition **COURSE DESIGNER:** Brian Hagen

START POSITION: Standing in box A hand above respective shoulders, gun loaded and holstered in ready condition per 8.1.1 and 8.1.2

STAGE PROCEDURE

Upon start signal engage each target as they become visible. Steel poppers and plate must be shot from box A. Steel must fall to score. The door is the fault line for the end of the alley way.

SCORING

SCORING: Comstock, 31 rounds, 155 points
TARGETS: 14 IPSC, 2 PP, 1 plate
SCORED HITS: Best per IPSC, steel down = 1A
START-STOP: Audible - Last shot
PENALTIES: Procedural. -10
 No-shoot hit. -10
 Miss. -10

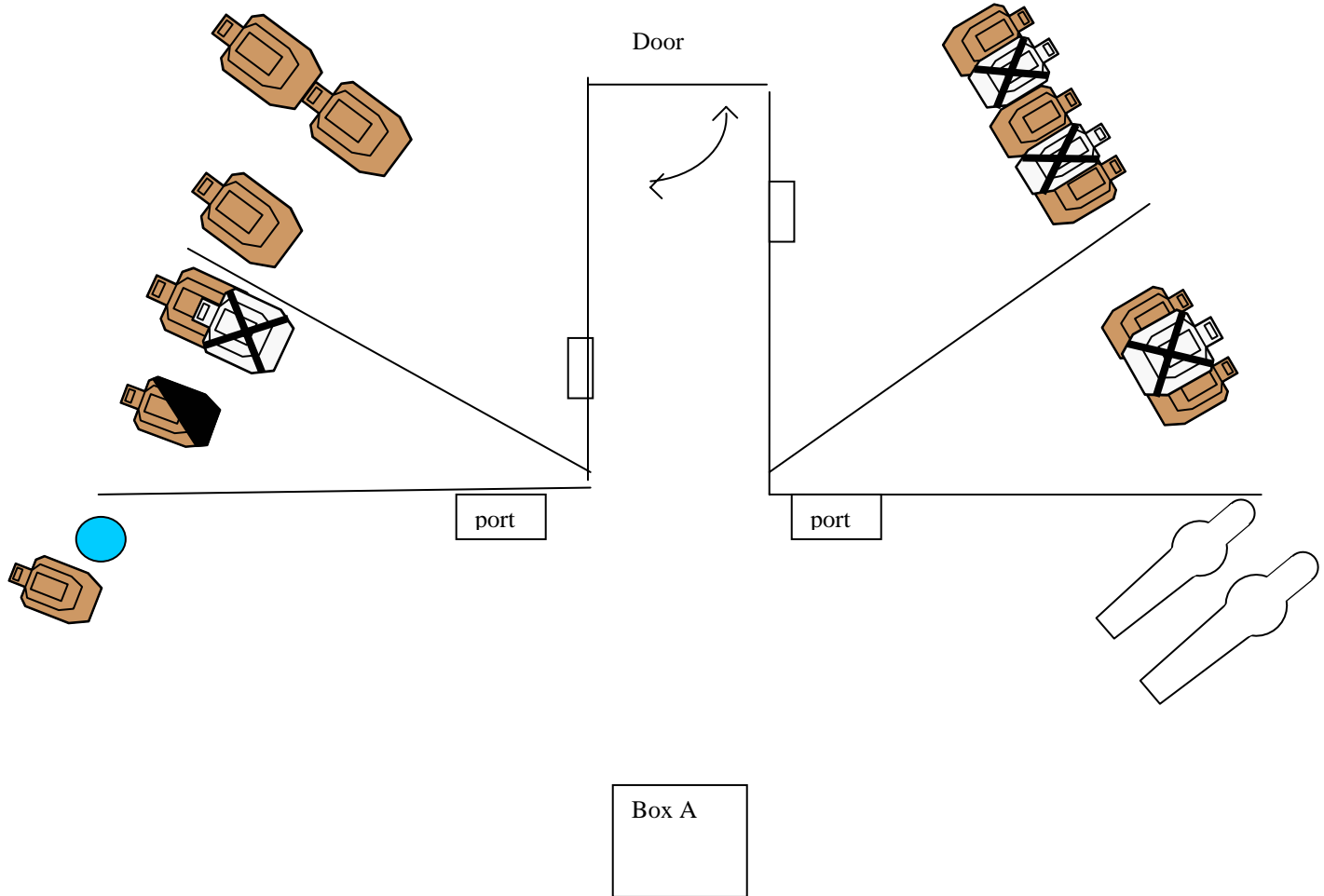

SETUP NOTES: The squares on the diagram are ports to shoot through. The door will be set up to open into the alley way.

RO NOTES:



CM 99-39

Off Balance Blast

RULES: Practical Shooting Handbook, Latest Edition **COURSE DESIGNER:** Scott Warren—Modifications by US Design Team

START POSITION: Standing in Box A facing barricade with both arms hanging relaxed at sides. Handgun is loaded and holstered as per ready condition in rule 8.1.1 and 8.1.2.

STAGE PROCEDURE

- String 1. Upon start signal, from Box A, engage T1-T3 from position 1 with only one round per target. Then, from Box A, re-engage T1-T3 from position 4 with only one round per target.
- String 2. Upon start signal, from Box A, engage T1-T3 from position 2 with only one round per target. Then, from Box A, re-engage T1-T3 from position 3 with only one round per target.
- String 3. Upon start signal, from Box A, engage T1-T3 from any position with only two rounds per target. Then make a mandatory reload and, from Box A, re-engage T1-T3 from a different position with only two rounds per target.

SCORING

SCORING: Virginia Count, 24 rounds, 120 points
TARGETS: 3 IPSC
SCORED HITS: Best 8/paper
START - STOP: Audible - Last shot
PENALTIES: Per current edition of USPSA Practical Shooting Handbook.
 Failure to perform the mandatory reload will result in one procedural penalty per shot fired.

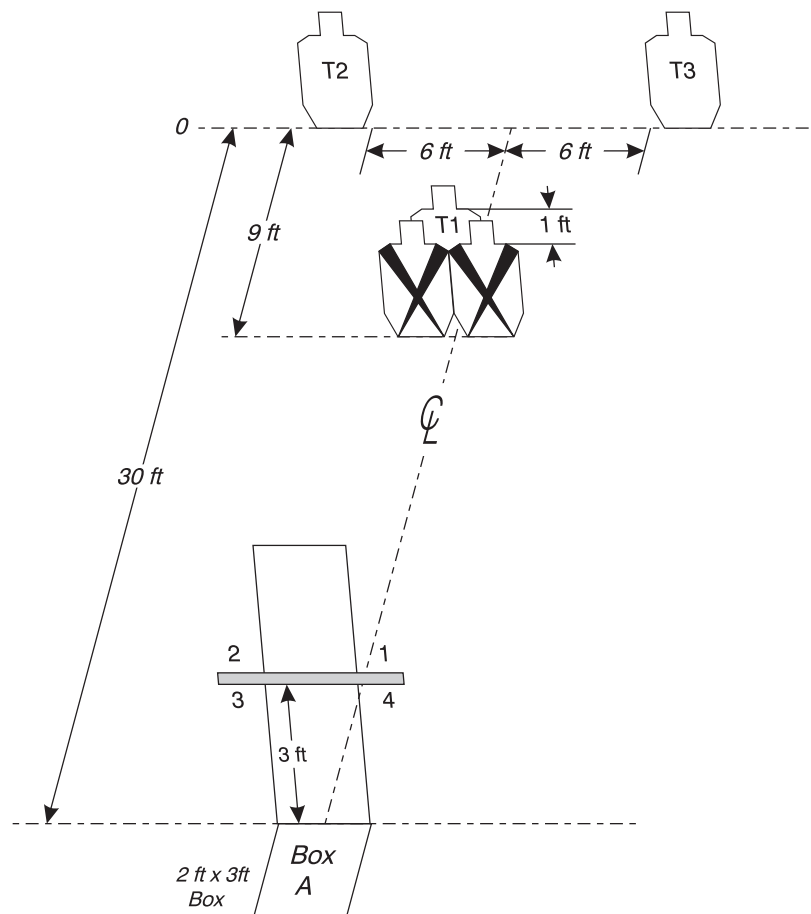

SETUP NOTES: Set paper targets to 5 feet high at shoulders. Barricade is 2 feet wide and 6 feet high with a four-foot-long 1x4 cross bar set 3 feet above ground. Ends of crossbar extend 1 foot to each side of barri-



cade. Target T1 is centered on barricade. The one foot distance from the shoulder of T1 to the shoulder of the no-shoots is measured from the top of non-scoring borders.